

Microcontrôleur

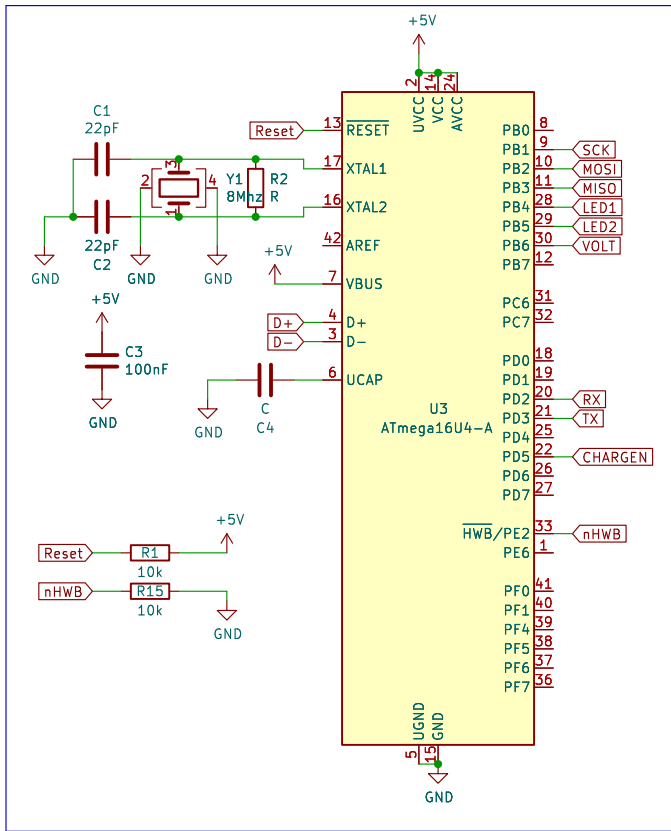

AVR ISP

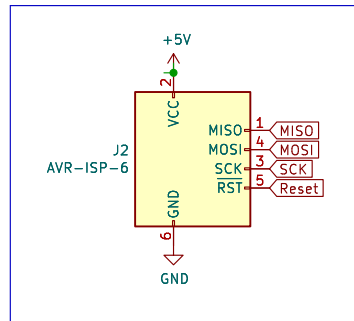

Utilisation batterie

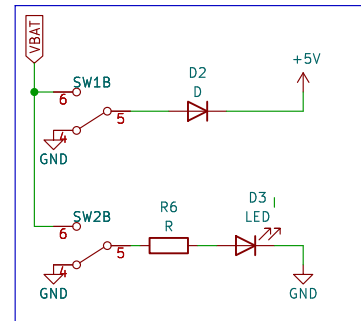

USB données et alimentation

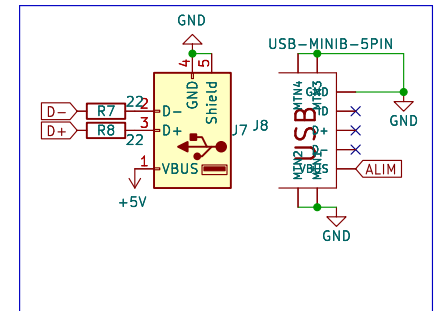

LED

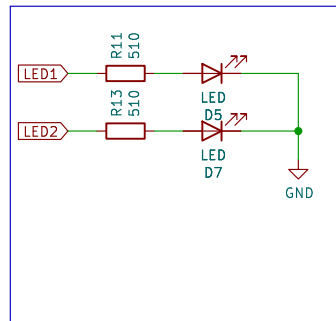

Chargeur LiPo

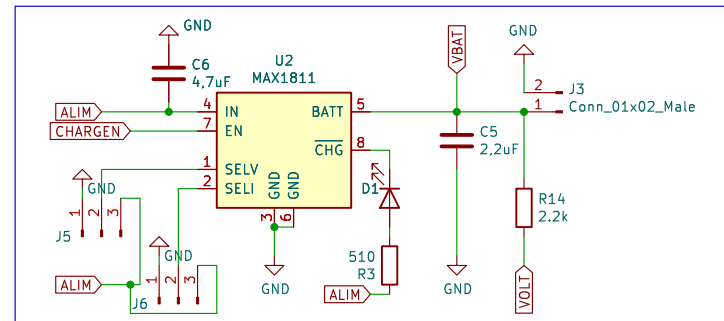

Série

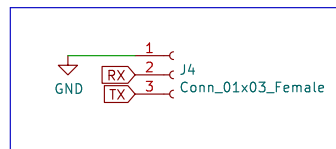

Sheet: /
File: ChargeurLIPO.kicad_sch

Title: Chargeur LIPO

Size: User Date:
KiCad E.D.A. kicad 7.0.2

Rev: Alpha
Id: 1/1